

WILSON ENGINEERING

CONTINUOUS BLOWDOWN HEAT RECOVERY SYSTEM

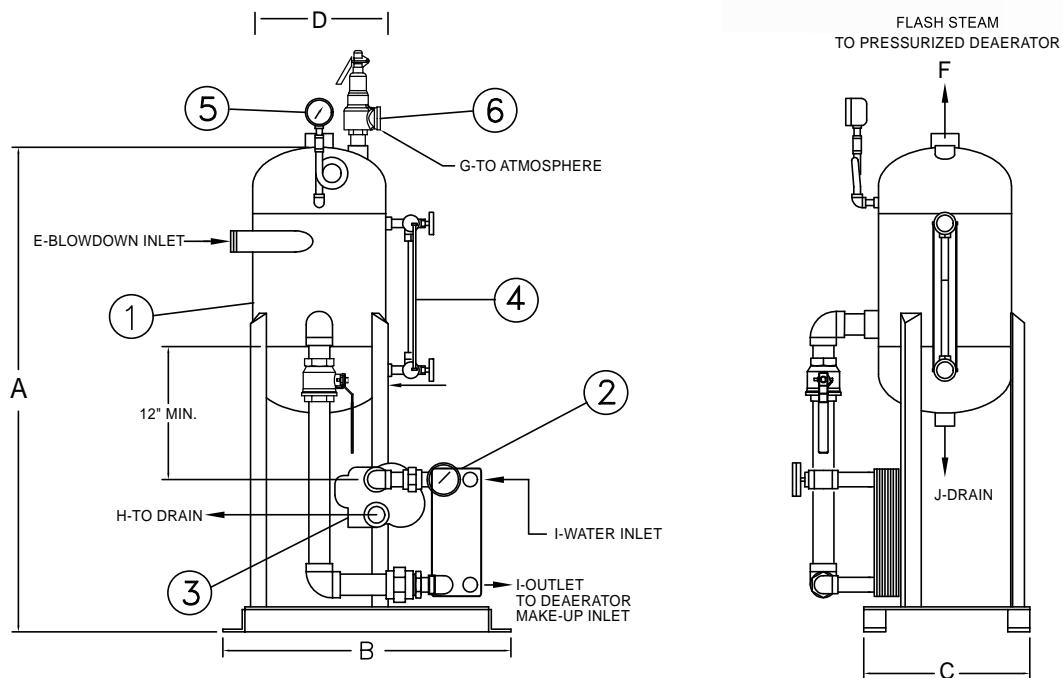

STANDARD COMPONENTS

- 1 FLASH RECEIVER-50LB. ASME CODE AND STAMPED
- 2 HEAT EXCHANGER-BRAZED PLATE
- 3 LEVEL CONTROL-F&T TRAP
- 4 WATER GAGE SET
- 5 PRESSURE GAGE
- 6 PRESSURE RELIEF VALVE (optional)

OPTIONAL COMPONENTS (not shown)

- THERMOMETERS
- SAMPLE COOLER
- SAMPLE VALVE(S)
- CONTINUOUS BLOWDOWN VALVE(S)
- HIGH WATER ALARM
- DRAIN VALVE
- BACKFLUSH PIPING AND VALVES

SYSTEM MODEL NUMBER	MAKEUP CAPACITY in lbs./hr*	DIMENSIONS IN INCHES										Shipping Weight Approx. in lbs.
		A	B	C	D	E	F	G	H	I	J	
CBHR-5	5,000	54	43	18	16	2	1 1/2	1 1/4	1	1	1 1/2	639
CBHR-10	10,000	54	43	18	16	2	1 1/2	1 1/4	1	1	1 1/2	645
CBHR-25	25,000	54	43	18	16	2	1 1/2	1 1/4	1 1/2	2	1 1/2	689
CBHR-50	50,000	54	43	18	16	2	2	1 1/4	2	2	1 1/2	689
CBHR-100	100,000	72	54	26	24	3	3	1 1/2	2	3	1 1/2	889

CONTINUOUS BLOWDOWN HEAT RECOVERY SYSTEM

Sample Specification

available for download
at www.wilsonblowdown.com

Provide one (1) Wilson CBHR designed to handle the continuous surface blowdown from _____(qty) boilers and a total connected boiler load of _____ horsepower. The total amount of surface blowdown to the flash receiver shall not exceed _____% of the total boiler load. The maximum makeup water to the boiler feedwater system will not exceed _____(#/hr or GPM).

Construction Summary

The flash receiver shall be ASME rated for 50 psig. Internal design shall insure complete separation of the boiler blowdown effluent from the flash steam. For inspection and cleanout, a 4" x 6" hand hole will be provided. The receiver shall be mounted on an "H" beam or HSS base and piped to the heat exchanger.

The heat exchanger shall be of the brazed plate type (optional plate/frame or shell/tube). Plates and nozzles shall be type 316 stainless steel. Optional: back flush piping shall be provided so that the heat exchanged can be isolated from the flash vessel and flushed with cold water back to drain.

Level control shall consist of a cast iron float and thermostatic (F&T) steam trap on the discharge of the heat exchanger. The F&T trap will continuously modulate cooled condensate to drain by maintaining the desired level in the flash vessel. Internal materials shall be 304 stainless steel with stainless steel seat and stainless steel valve.

The flash vessel, heat exchanger, and level controller shall be factory mounted and piped in a complete system prior to shipment. Unit shall be self contained; no external utility connections for electricity or instrument air are required for operation.

Calculate Your Energy Savings

Gather the following information and then visit our online Energy Savings Calculator at: www.WilsonBlowdown.com

- _____ Total Boiler Load
- _____ Boiler Operating Pressure
- _____ % Continuous Surface Blowdown
- _____ % Makeup
- _____ Makeup Temperature

ADDITIONAL WILSON PRODUCTS



BOILER BLOWDOWN SYSTEMS



BLOWDOWN TANKS



EXHAUST HEADS