



# Boiler Feedwater Systems

• Low Cost • Efficient • Easy to Install

## Features

1. Receiver factory mounted on stand.
2. Bronze float type make-up valve.
3. Stainless steel temperature gauge.
4. Bronze water gauge cocks with 5/8" red line gauge glass.
5. Centrifugal boiler feed pumps.
6. Suction piping including shut-off valve.
7. Magnetic starters for each pump with enclosure.
8. Hand-Off-Auto switch in each starter enclosure.

## Horizontal Boiler Feedwater Systems

The AFS line of feedwater systems is available in seven sizes to fit most firetube and commercial watertube boiler applications: Sizes are 50, 100, 200, 300, 500, 750 and 1,000 gallons of storage capacity.

- The standard packaged design is shipped complete with the pumps and pump suction piping factory installed. Most components are factory installed to make it easier to get the boiler feedwater system installed with minimum cost and effort.

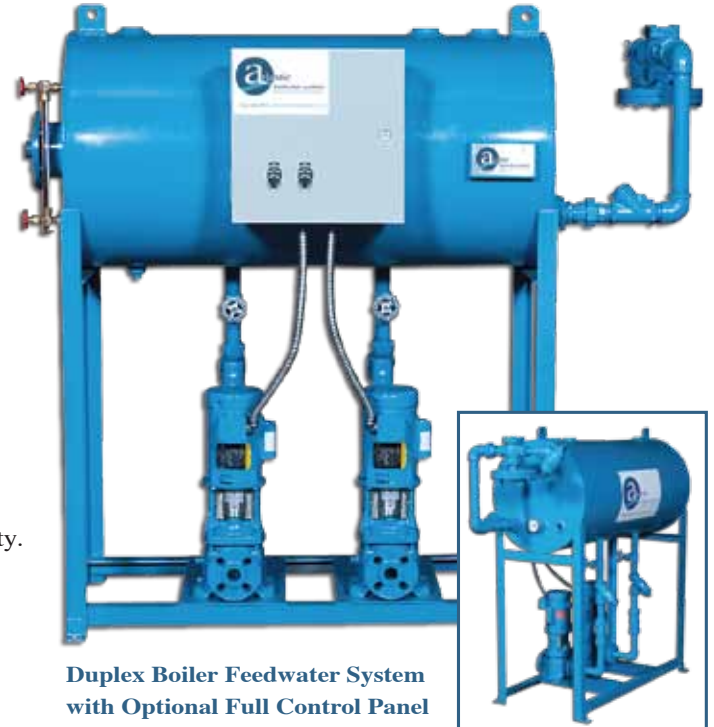

**Duplex Boiler Feedwater System with Optional Full Control Panel and Steam Heat Assembly.**



**Close up of two boiler feed pumps installed on the 100 FS Compact Boiler Feedwater System**

## CENTRIFUGAL BOILER FEED PUMPS

**1. Pump size matched to tank size for easy selection.**

**2. Centrifugal pumps provided with all models.**

Centrifugal pumps are used on all low pressure and high pressure steam units. Centrifugal pumps are more efficient than turbine type pumps, which reduces electrical use, saving money on utility bills. The centrifugal pumps also require less maintenance. Turbine pumps are available upon request.

*Single stage centrifugals are used on the low pressure steam systems. (Vertical is optional.) Multistage vertical centrifugal pumps are used on the high pressure steam systems.*

# Packaged Boiler Feedwater Systems

## CORROSION RESISTANT OPTIONS

Many feedwater systems fail prematurely due to the corrosive effects of condensate and oxygenated make-up water. If the feedwater system experiences significant levels of make-up and steam is used for feedwater preheat in the feedwater system, a standard "carbon steel" vessel may fail prematurely.

The corrosion resistant options available are:

- 304 Stainless Steel vessel
- Duratherm lining (100 to 1,000 gallon)
- Hot Dipped Galvanized vessel

*The higher the level of make-up, the greater the need for a corrosion resistant lining.*

## STEAM PREHEAT

A steam preheat assembly is recommended if the blended makeup/condensate return temperature is lower than 140F. This component includes a self contained temperature control valve, check valve, and copper sparge tube to evenly distribute the steam under the water line of the feedwater system.

## ELECTRICAL OPTIONS

Our standard feedwater systems include a starter for each pump enclosed in a common Nema 1 panel and wired to the motors. Additional options include door disconnect, control circuit transformer, alarm switches, fuse protection, alternator (for on/off operation only), UL label, and Nema 12/4/4x panels.

## QUICK SHIPMENT

The standard feedwater systems are available in 3 to 4 weeks. If you need a system now to replace a unit which has failed or for a quick turn project, we offer expedited shipment at a nominal charge. *Several sizes are in stock for quick shipment.*

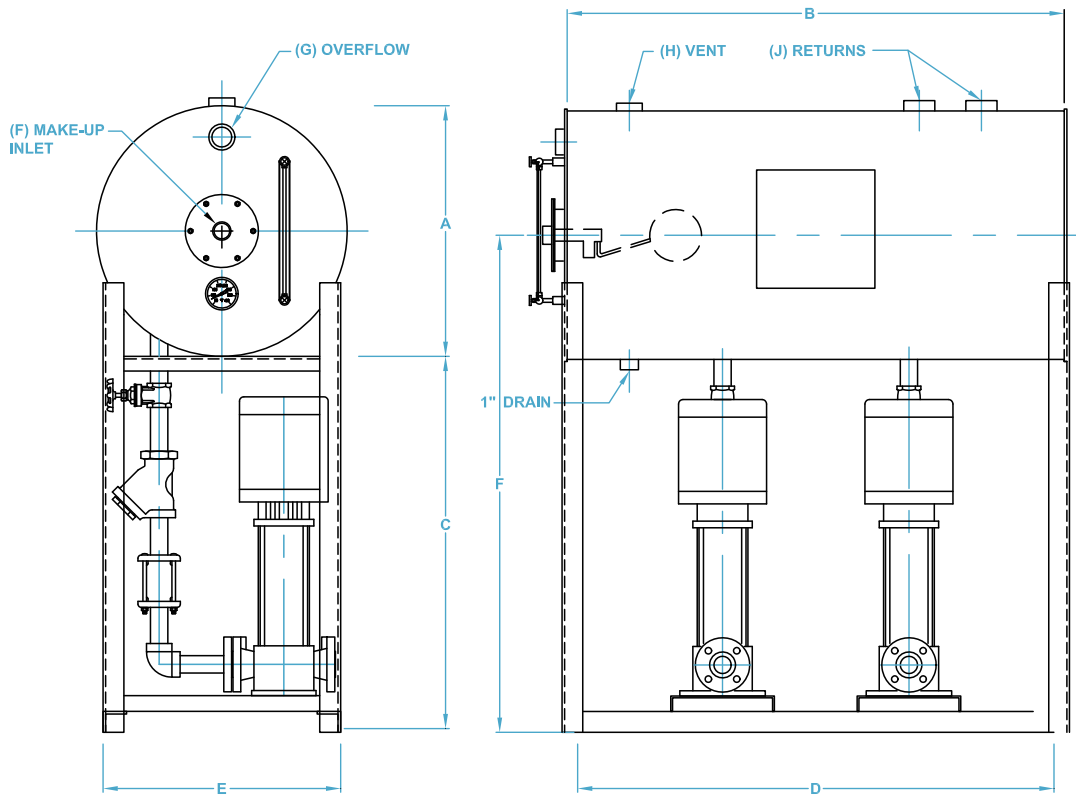

## OPTIONS

- Solenoid Makeup Valve
- Alarm Switches (level)
- Discharge Piping
- Chemical Quill
- 3-valve Bypass
- Bolted Stand
- Lowboy Arrangement

MODEL	CAPACITY IN GALLONS	RECEIVER		STAND			MAKE-UP CENTERLINE	OVERFLOW OUTLET	VENT OUTLET	RETURN INLET
		O.D.	LENGTH	HEIGHT	LENGTH	WIDTH				
		A	B	C	D	E	F	G	H	J
50	48	24	24	36	22	22-3/4	ADD 1/2 O.D. TO STAND HEIGHT	1-1/2	1-1/2	2
100	94	24	48	36	46	22-3/4		1-1/2	1-1/2	2
200	220	30	72	48	70	27-1/2		2	2	3
300	330	36	72	48	70	32		3	3	3
500	470	48	60	48	56	40		3	4	3
750	752	48	96	48	92	40		3	4	3
1000	940	48	120	48	108	40	3	4	3	

### NOTES:

1. ALL DIMENSIONS IN INCHES UNLESS OTHERWISE NOTED.
2. Y-STRAINERS SHOWN ARE OPTIONAL.
3. STANDARD STAND HEIGHTS ARE LISTED. OTHER HEIGHTS ARE AVAILABLE BY REQUEST.
4. MAKE-UP INLET (K) IS DETERMINED BY SYSTEM CAPACITY.
5. ONE, TWO, OR THREE BOILER FEED PUMPS CAN BE ACCOMMODATED INTO STAND.

